

Short Reports

MODEL A LOW POWER THE WIND GENERATOR SETUP

Semenov A.S.

North-Eastern Federal University named after M.K. Ammosov, pulpit of Electrification and automatization mining industry, Mirny, Sakha, e-mail: sash-alex@yandex.ru

In this short report we create a model of a low power wind generator setup using MatLab programs based on stepper motor. The substantiation of creating a model, built a model, the results obtained by the rectified voltage at the output of the generator.

In the coming decades, the residents of the planet Earth expects shortage of energy resources. Market volatility extraction and processing of oil and gas, led the search for alternative energy sources, particularly wind power. Scientists around the world have been searching for the inexhaustible sources of energy. Wind energy – one of the most promising areas of energy, providing a source of energy makes up for mankind. Wind turbines use wind energy by converting it into an electrical current. This area of energy systems using a wind turbine to solve a lot of problems for the effective energy supply remote from urban communications suburban houses, villages and farms. Wind turbines can gain independence and autonomy of the local energy suppliers.

The use of wind turbines is very economical, and in contrast to other methods of obtaining

energy requires no resources and natural materials. Wind turbines produce cheap electricity, and in the presence of constant wind – a fully autonomous. In addition, the use of wind turbines do not cause any harm to the natural environment and ecology.

Wind turbines are the power plants, which include: in fact, wind generator, batteries, inverter, charge controller, wind wheel with blades. To meet the needs of a small country house, if the average wind speed is consistently exceed 4 m/s, it is enough wind turbine capacity of about 1 kW, which will provide electricity to the basic need for electricity: lighting, telephone, television, radio and other low-power devices. To ensure high performance electrical energy wind generator, it should be placed on the sublime and the open, fan cooled stable air flow.

As an example of a wind generator setup assemble a mathematical model based on the low-power turbine stepper motor using MatLab [1]. To create the model wind generator setup will use two sources of power (simulated stepper motor), the rectifying diodes, capacitors, voltage regulators (resistor). First collect the rectifier. For each phase of the stepper motor (it is four-phase) will be used for the diode 2, i.e. a total of 8 diodes. The output voltage is stabilized by means of a capacitor of 1000 uF and voltage regulator (resistor with a resistance of 50 ohms). The assembled model is shown in the Fig. 1.

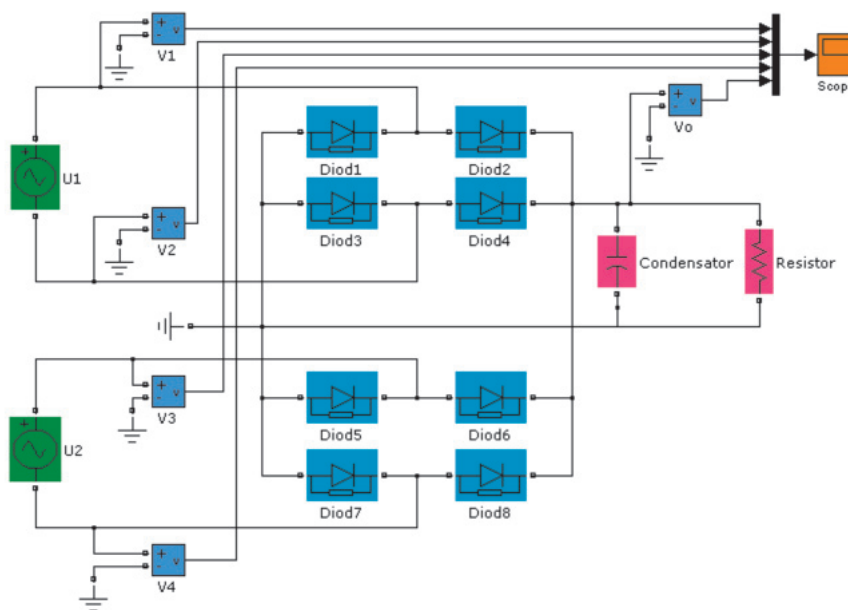

Fig. 1. Mathematical model of a low-power wind generator setup on the basis of the steppermotor in the program MATLAB

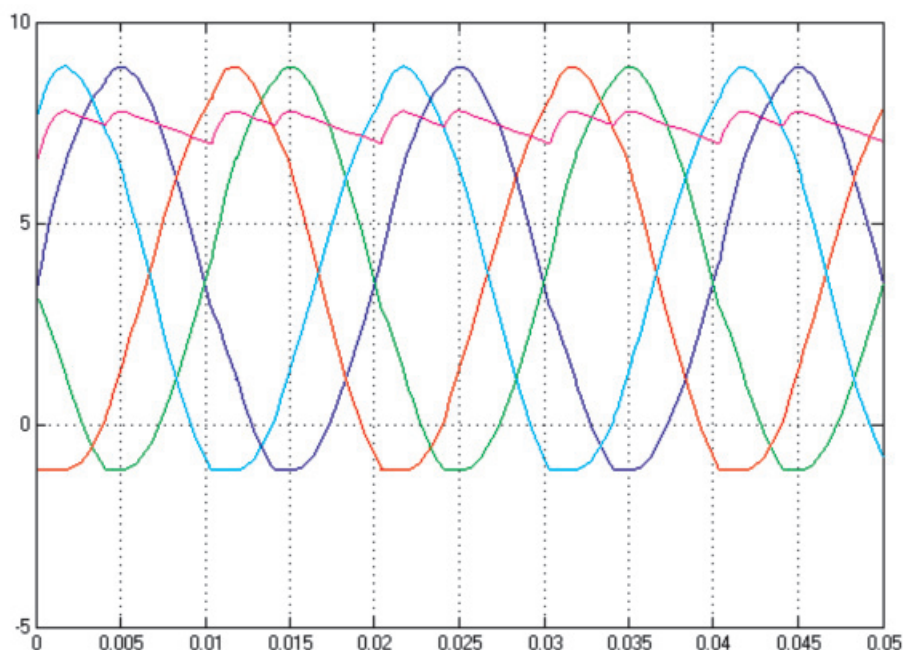

Fig. 2. Results of modeling wind generator installation

With voltage meter V1...V4 graphics get a sine wave four phases of the motor. Vo voltage meter shows the shape and magnitude of the voltage generated by the wind turbine. It is about 7 volts. Graphics are shown in the fig. 2 [2].

This model of the wind generator set can be used in practice only for low-power electrical appliances. But when replacing the stepper motor to the induction and increasing the size of the wind turbine blades, it is possible to get the power up to 1 kW, and the output voltage of 220–380 V [3].

References

1. Semenov A.S., Rushkin E.I. Model of a low power wind generator setup / Erel-2011 // Proceedings of the conference of young scientists. / [Br. Ed.: I.I. Khristophorov et al.] – Yakutsk: Univ. Ltd. «Tsumori Press», 2011. – Volume 1. – P. 140–143.
2. Semenov A.S., Shipulin V.S., Rushkin E.I. Simulation modes of micro hydro and wind generator setup / Modern research in the field of energy conservation and energy efficiency // Fri. Scientific. Art. Materials I Intern. Scientific. – Pract. Conf. / Editorial Board: A. Filonovich (Ed.). [Et al.]. – Kursk: South-West. State. University Press, 2012. – P. 102–107.
3. Semenov A.S., Shipulin V.S., Rushkin E.I., Savvinov P.V., Ereemeeva R.E. Prospects for the use of renewable energy sources in the Republic of Sakha (Yakutia) // Alternative Energy and Ecology. – 2013. – № 03 (121). – P. 138–142.